HANDLING, STORAGE & DELIVERY STANDARD

1. BASIC STANDARD

A) The location of center of gravity of pole

The red-dot marked on the surface of each pole indicates the location center of gravity of the pole, as shown in Figure 1.

The location of the center gravity is important to ensure that the pole will be kept balanced during lifting work.

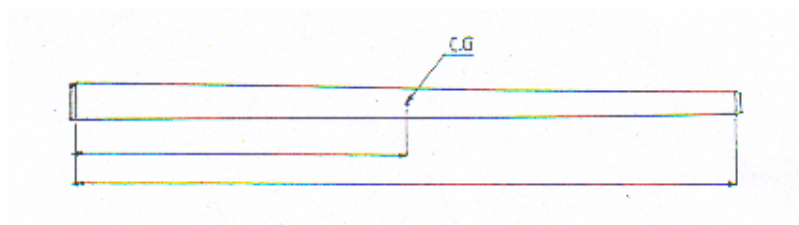

Figure 1

B) Pole Weight

The specification of poles does not permit any minus allowance for the concrete wall thickness. Normally, the actual weight of each pole is usually heavier by several percentage than the nominal weight.

C) Wire ropes used for handling work of poles

The wire ropes used for the handling work of the poles should have sufficient capacities for the weight of the pole or poles to be lifted. The diameters of the wire ropes and the safe loads which the ropes can suspend are shown in Table-1.

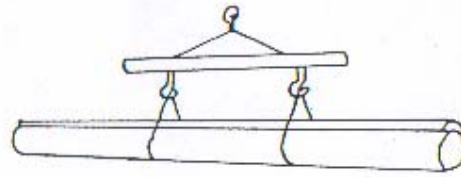

Case I

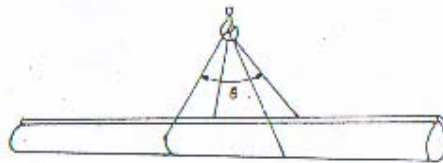

Case II

Diameter of Wire Rope		Ultimate Tensile Strength	Case I (1000 16f)	Case II (Kips)						
				θ : Suspension Angle						
Mm	Inch	kips	kips	20°	30°	40°	50°	60°	90°	120°
8.0	5/16	7.1	4.6	4.6	4.4	4.4	4.2	4.0	3.5	2.2
9.0	11/32	8.8	5.7	5.7	5.7	5.5	5.3	5.1	4.2	2.9
10.0	25/64	11.0	7.1	7.1	7.1	6.8	6.6	6.2	5.1	3.5
12.0	16/32	15.9	10.4	10.4	10.1	9.9	9.5	9.0	7.5	5.3
12.5	31/64	17.2	11.2	11.2	11.0	10.8	10.4	9.9	7.9	5.7
14.0	35/64	21.6	14.1	14.1	13.9	13.7	13.0	12.3	10.1	7.1
16.0	5/8	28.2	18.3	18.3	18.1	17.6	17.0	16.1	13.2	9.3
18.0	45/64	35.7	23.4	23.4	22.9	22.5	21.4	20.5	16.8	11.7
20.0	25/32	44.3	28.9	28.9	28.4	28.0	26.7	25.6	20.7	14.5
22.4	7/8	55.5	36.4	36.4	35.7	35.0	33.5	32.0	26.0	18.3
25.0	63/64	69.0	45.2	45.2	44.3	43.4	41.4	39.7	32.4	22.9
28.0	1-3/32	86.6	56.6	56.6	55.5	54.7	52.2	49.8	40.8	28.7
30.0	1-3/16	99.4	65.0	65.0	68.9	62.8	62.8	57.3	46.7	33.1

Table - I

D) Dunnage and wedge to be used for handling or storing poles

Figure 2 shows the dunnage to be used for handling or storing poles.

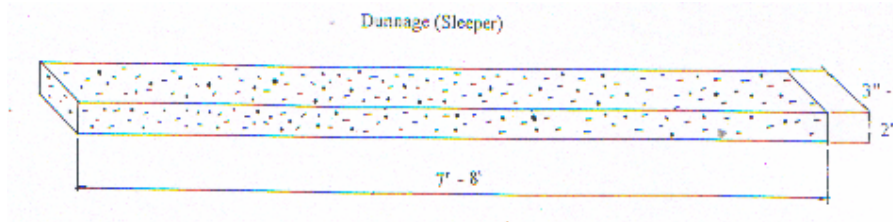

Figure 2

Figure 3 shows the wedges to be used in conjunction with the dunnage.

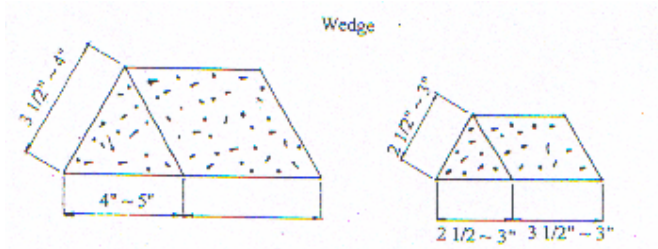

Figure 3

E) Equipment for loading and unloading poles

i. Crane

A derrick crane, gantry crane, truck crane, or jib crane is most usually used.

In such case, the use of beam for this purpose, as shown below, is desirable.

Length of beam : 7' - 10'

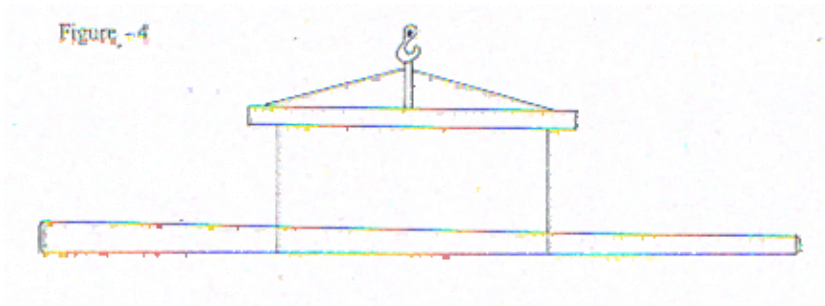

F) Storage / Staking of Poles At Factory Stockyard

- a. The poles shall be stacked/piled on a level concrete beam.
- b. The poles should be stored in the manner shown in Figure 5a and 5b, and should not be piled higher than four distributed heavier load layers, as it could be dangerous to the public/workers.
- c. The dunnage must be in straight position to the concrete beam as shown in Figure 5a.
- d. The wooden wedges are placed for every four poles as shown in Figure 5b.
- e. Standard quantity of poles per lot is 60 nos (15 poles x 4 layers)

Figure 5a



Figure 5b

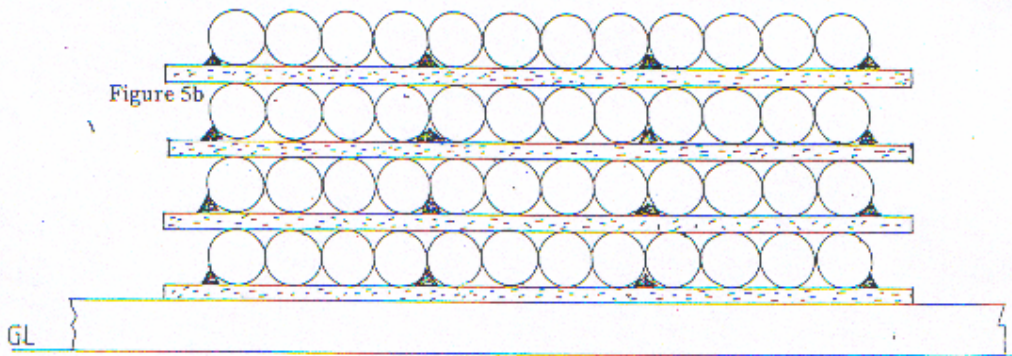

2. HANDLING DURING TRANSPORTATION AND DELIVERY

2.1 Inland Transportation

A) Vehicles suitable for inland transportation

A trailer-truck with a loading bed no less than 12m in length is desirable to be used for transportation, while a pole-trailer of the kind shown in Figure 7 may also be used.

Figure-7



B) Loading work

- i. Poles (A) should be placed on sleepers fixed on the loading bed of the truck. When poles (B) are loaded on the poles (A), the poles (B) should be placed on dunnages set about $\frac{3}{5}$ of over all pole length apart each other on the poles (A) as shown in Figure 8.

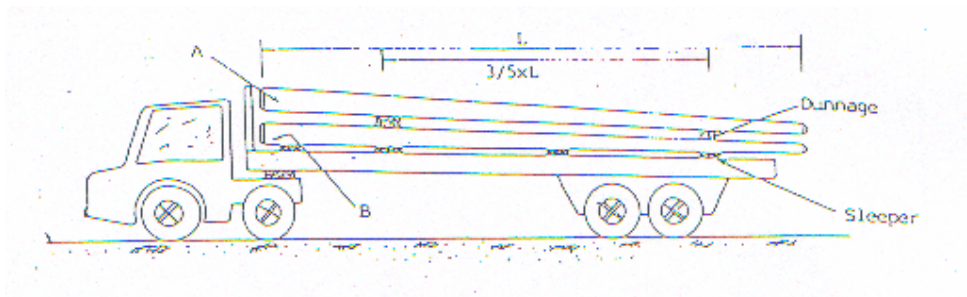

- ii. The loading of poles onto a truck should start from the center of the loading bed of the truck as shown in Figure 9, not from the side of the bed as shown in Figure 10.

If loading starts at the side, the bed will incline and cause the poles to fall from the truck.

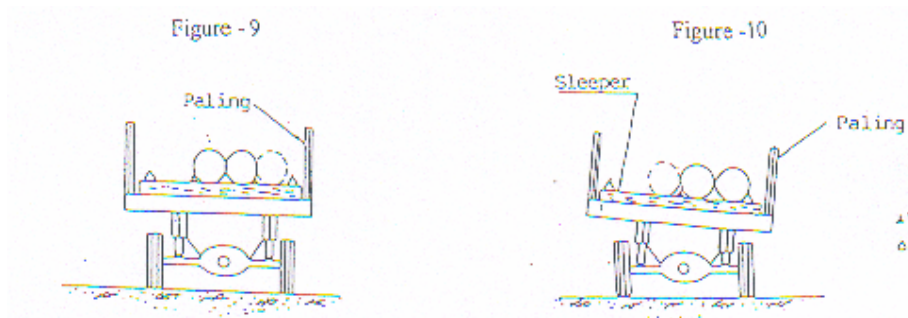

- iii. Before commencement of loading, iron wedges of the type shown in Figure 11 should be fixed without fail at the edge of each sleeper shown in Figure 9 (a total of four places), and Wooden Wedges should not be used for this purpose. This is a most important point for preventing the poles from falling from the truck during loading operation.

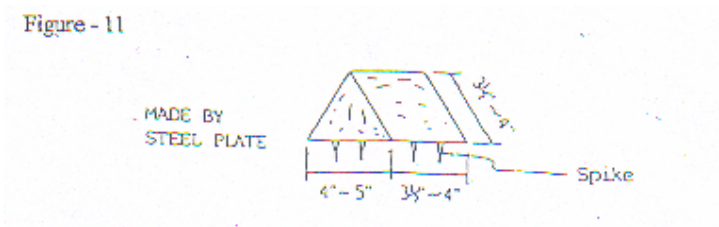

- iv. The standard quantity of poles to be loaded onto a truck are summarized in the Table 2 according to product size and capacity of lorry.
- v. The poles should be loaded on the truck as shown in Figure 12 and Figure 13. Palings must be installed and used exactly as shown in these Figure as to prevent the poles from falling.

The wire ropes to be used for fixing the poles should be rigidly tightened with a turn-buckle, etc and carefully inspected to make sure there is no looseness.

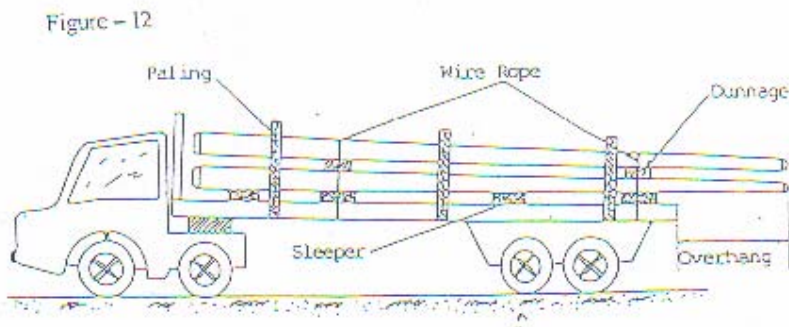

The length of the overhang shall not exceeds 4m.

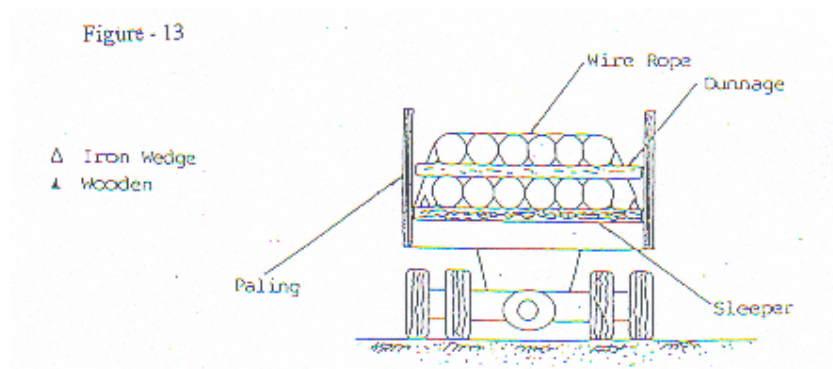

The wooden wedges should be nailed to ensure they are not loosen.

C) Operation of Vehicles

- i. Prior to the operation of the vehicle, it is absolutely necessary to check that the wedges are firmly fixed between the poles and the dunnages or sleepers, that they are nailed and that the wire ropes are properly fastened and tightened.
- ii. Sudden starts or stops of a vehicles should be avoided at all time because it could cause the load to break loose.

The speed of the vehicle should always be considerably reduced on curves because high-speed turns could cause the vehicles to roll over.

- iii. Any breaking up of the vehicle should be directed by an assistant who is to alight from the vehicle and to stand in a safe position where he can be seen by the driver.

(It is further recommended that the directions for backing be conducted by the blowing of a whistle)

D) Unloading

- i. No unloading work should be carried out when the vehicle is leaning to one side or another because the poles may suddenly roll off the vehicle if the work is commenced under such conditions.
- ii. Unloading of the poles should be carried out by alternately removing a pole from first one side and then the other, reversing the loading procedure, to keep the weight as evenly distributed as possible so as to prevent any extreme inclination of the truck bed. (Please refer to Figure 9 and Figure 10)
- iii. After a pole is lifted by the crane and is no longer in contact with the dunnage, the wedges that had been holding that pole should be unfastened and shifted to the adjacent pole as soon as possible.
- iv. When the poles are unloaded onto the surface of the ground, the work should be carried out in accordance with paragraph 2-C, Unloading from a ship. During this operation, too, it is imperative that any bumping of poles against each other be avoided; the poles should also be prevented from receiving any sharp or sudden impact.

2. STORAGE / STACKING OF POLES AT SITE

- A) The storage of poles shall be made on a firm/solid surface of level ground.
- B) The poles shall be stored in accordance to the Figure 14, and should not be piled higher than three layers, because poles piled higher than this are likely to place a severe load on the ground and might cause an uneven settlement of the earth and a breaking loose of the poles.

Figure - 14

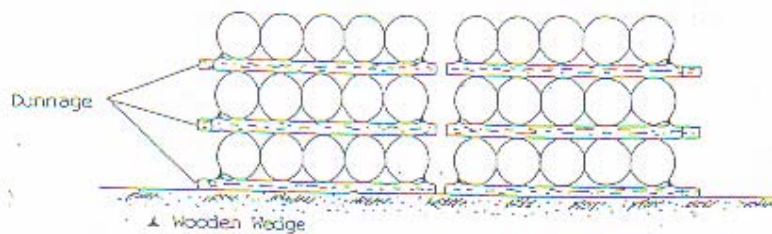

(Side view of the above drawing can be referred to Figure 5a)

Safety regulation as established at site shall be strictly followed. All the warning sign shall be installed at the correct position.

- C) The wooden wedges should always be firmly nailed in place.
- D) Handling manually by using manpower shall be avoided.